



VA6200 Series Sequential Switcher



C841M-A (7/02)

CONTENTS

Section	Page
IMPORTANT SAFEGUARDS AND WARNINGS	3
DESCRIPTION	3
MODELS	3
INSTALLATION	4
OPERATION	9
SEQUENCING	9
VIEWING THE STATUS OF CAMERAS IN A SEQUENCE	9
CHANGING THE STATUS OF A SINGLE CAMERA IN A SEQUENCE	9
CHANGING THE STATUS OF MULTIPLE CAMERAS IN A SEQUENCE	9
DWELL TIME	10
CAMERA TITLING	10
ALARMS	11
EXTERNAL TRIGGER	11
POWER-UP DEFAULT SETTINGS	11
TROUBLESHOOTING	12
SPECIFICATIONS	13
WARRANTY AND RETURN INFORMATION	15

LIST OF ILLUSTRATIONS

Figure	Page
1 Jumper Settings - VA6200 Series	4
2 Fixed Cameras with Terminated Inputs	6
3 Fixed Cameras with Looping Outputs	6
4 Movable Cameras with Terminated Inputs and Coaxitron Control	7
5 Movable Cameras with Looping Outputs and Coaxitron Control	7
6 Connector Assembly	8
7 Camera Status	9

LIST OF TABLES

Table	Page
A Jumper Settings - VA6200 Series	5
B Video Coaxial Cable Requirements	5
C Fuse Table	12

IMPORTANT SAFEGUARDS AND WARNINGS

Prior to installation and use of this product, the following WARNINGS should be observed.

1. Installation and servicing should be done only by qualified service personnel and conform to all local codes.
2. Unless the unit is specifically marked as a NEMA Type 3, 3R, 3S, 4, 4X, 6 or 6P enclosure, it is designed for indoor use only and it must not be installed where exposed to rain and moisture.
3. Use only replacement parts recommended by Pelco.

DESCRIPTION

The VA6200 Series Sequential Switchers manually or automatically switch multiple cameras to a monitor. You can switch up to 20, 12, 8, or 4 cameras to 1 or 2 monitors, depending on the model you have.

The switcher's second monitor output can be connected to a monitor and/or a Coaxitron® controller. The switchers have an alarm input for each camera and camera ID, and an external trigger to control camera sequencing remotely.

MODELS

VA6204	Sequential switcher with 4 camera and 4 alarm inputs, and 2 monitor outputs, 120 VAC
VA6204-X	Same as the VA6204 except 230 VAC
VA6208	Sequential switcher with 8 camera and 8 alarm inputs, and 2 monitor outputs, 120 VAC
VA6208-X	Same as the VA6208 except 230 VAC
VA6212	Sequential switcher with 12 camera and 12 alarm inputs, and 2 monitor outputs, 120 VAC
VA6212-X	Same as the VA6212 except 230 VAC
VA6220	Sequential switcher with 20 camera and 20 alarm inputs, and 2 monitor outputs, 120 VAC
VA6220-X	Same as the VA6220 except 230 VAC

INSTALLATION

1. Remove the cover from the switcher.
2. Set the jumpers as required for your application. Refer to Figure 1 and Table A.
3. Replace the cover.
4. Place the unit on a flat surface or install it in an equipment rack using the appropriate rack-mount kit.
5. Make all equipment connections to the switcher. Refer to Figure 2. Refer to Table B for the type of coaxial cable to use. Only MON 2 output is Coaxitron compatible.

NOTE: The VA6220 switcher is supplied with factory-installed rack ears for mounting in a standard 19-inch rack mount. The rack ears can be removed when using a VA6220 in a desktop application.

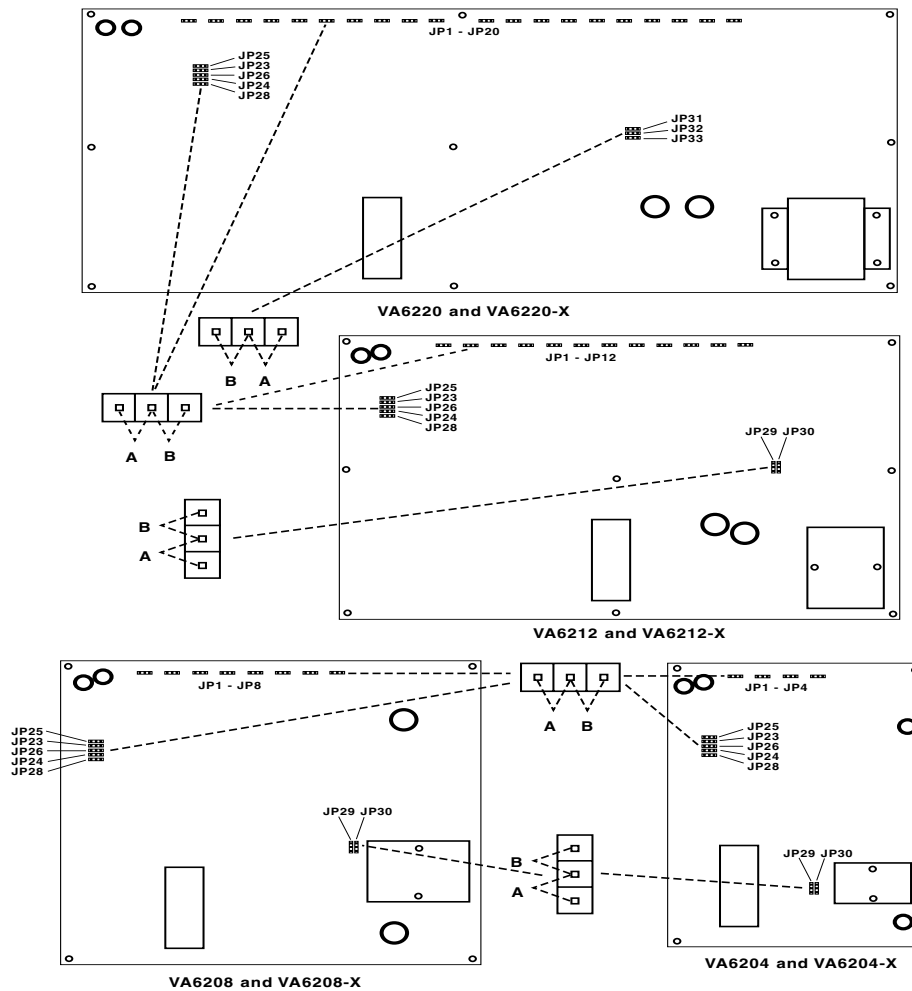

Figure 1. Jumper Settings - VA6200 Series

Table A. Jumper Settings - VA6200 Series

Jumper	Position	Function
JP1 - JP20	A	Camera input terminated (75 ohms)
	B	Camera input looping (high impedance)
JP23, JP24, JP25, JP26, JP28, JP31	A	Camera titles on Monitor 1
	B	Camera titles on Monitor 2
JP29 or JP32	A	PAL video standard
	B	NTSC video standard
JP30 or JP33	A	Standard character set
	B	Extended character set
Standard character set: 0-9, A-Z, punctuation Extended character set: Standard character set plus lower case letters, symbols, and kanji and katakana characters		

Table B. Video Coaxial Cable Requirements

Cable Type*	Maximum Distance
RG59/U	750 ft (229 m)
RG6/U	1,000 ft (305 m)
RG11/U	1,500 ft (457 m)

*Minimum cable requirements:

75 ohms impedance

All-copper center conductor

All-copper braided shield with 95% braid coverage

6. Wire the alarm inputs, alarm output, and external trigger directly. Refer to Figure 6 to build a cable using either the 15-pin or 25-pin D-type mating connector that is supplied with the switcher.

The alarm inputs require a ground signal to activate them. There is one alarm input for each camera. For example, an alarm on input 5 directs the switcher to select camera 5.

The alarm output is a relay with normally open (N.O.) and normally closed (N.C.) contacts. This connection is intended to activate an external device, such as a VCR, when there is an alarm. Refer to the *Specifications* section for the voltage and current ratings of the relay.

The external trigger is an input connection. It is for use with time-lapse recorders that have an external trigger output to control the sequencing of cameras.

7. Plug in the power cord. The switcher begins operating.
8. Synchronize the cameras if there is vertical roll when switching between cameras. Refer to the instruction manuals supplied with the cameras.

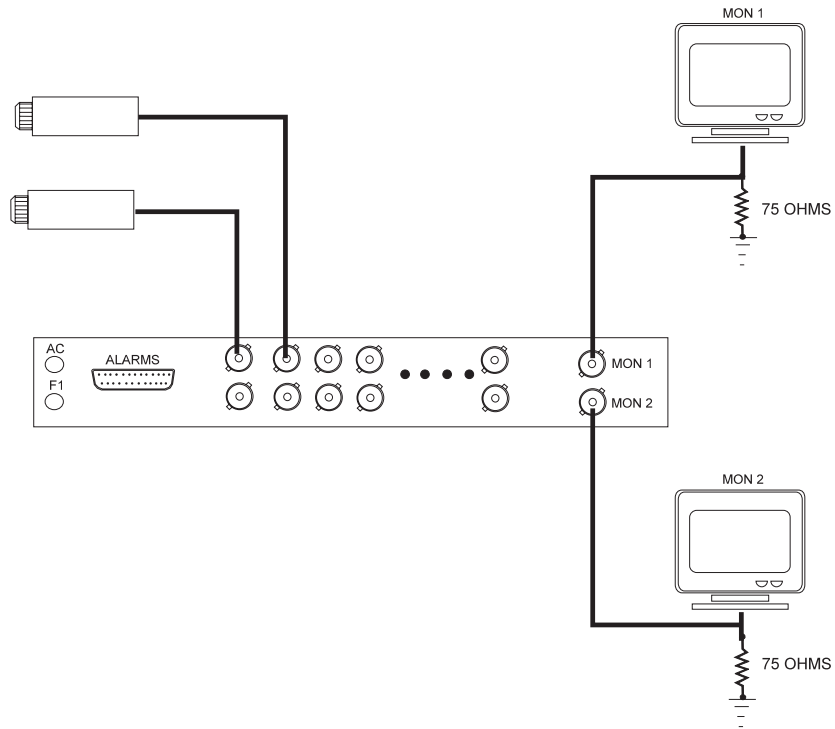

Figure 2. Fixed Cameras with Terminated Inputs

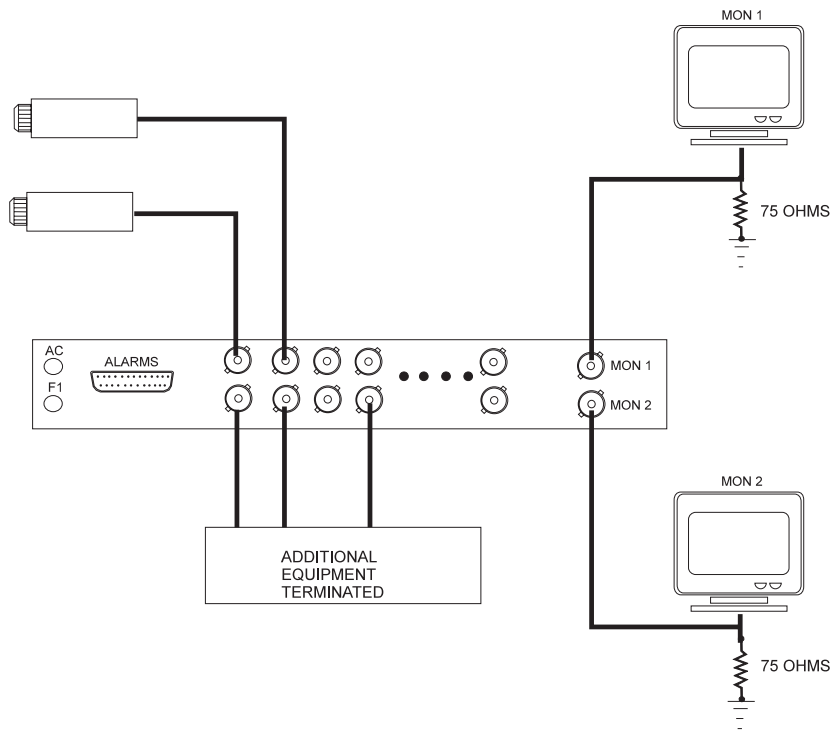

Figure 3. Fixed Cameras with Looping Outputs

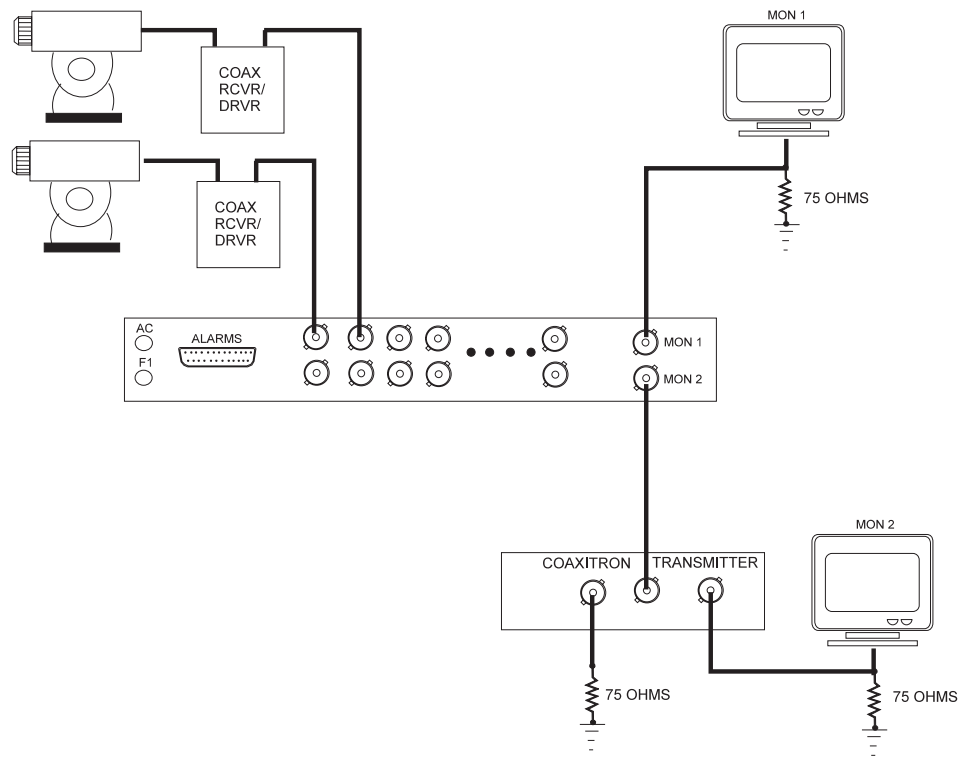

Figure 4. Movable Cameras with Terminated Inputs and Coaxitron Control

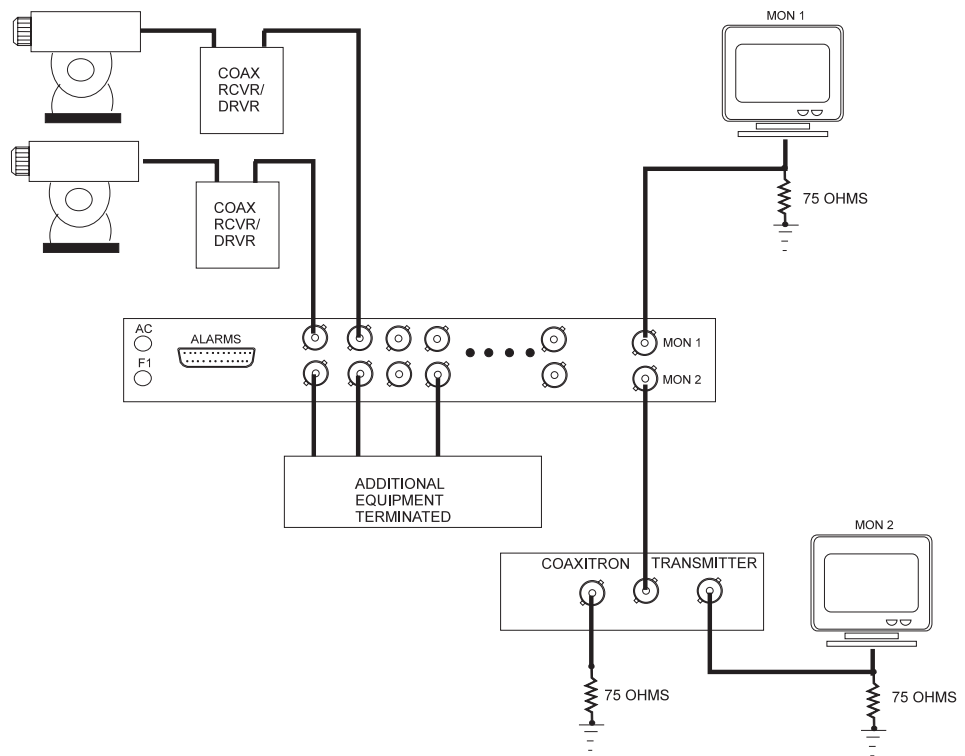
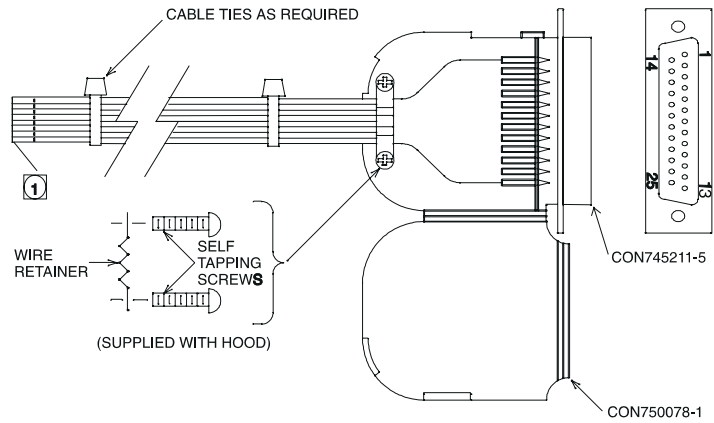

Figure 5. Movable Cameras with Looping Outputs and Coaxitron Control

WIRING CHART (DB25 CONNECTOR)

PIN	FUNCTION	
1	12 INPUT ALARM MODELS	
2		
3		
4		
5		
6		
7		
8		
9		
10		
11		
12		
13	20 INPUT ALARM MODELS	
14		
15		
16		
17		
18		
19		
20		
21		RELAY N.O.
22		RELAY COMMON
23		RELAY N.C.
24		EXTERNAL TRIGGER
25	COMMON (ALARM/EXT/TRIG)	



WIRING CHART (DB15 CONNECTOR)

PIN	FUNCTION	
1	4 INPUT ALARM MODELS	
2		
3		
4		
5	8 INPUT ALARM MODELS	
6		
7		
8		
9	20 INPUT ALARM MODELS	
10		
11		RELAY N.O.
12		RELAY COMMON
13		RELAY N.C.
14		EXTERNAL TRIGGER
15		COMMON (ALARM/EXT/TRIG)

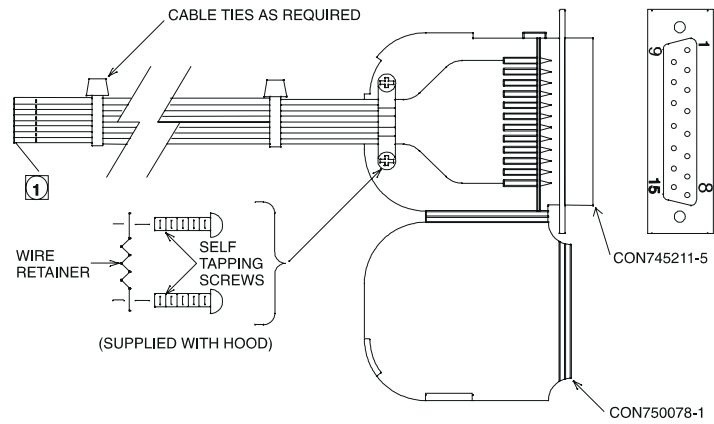

Figure 6. Connector Assembly

OPERATION

To operate the VA6200 Series Switcher:

1. Plug in the power cord.
2. Select the monitor by pushing the MON 1 or MON 2 button.
3. Press a camera button to view video from the corresponding camera.

SEQUENCING

To run a sequence:

1. Select a monitor by pushing the MON 1 or MON 2 button.
2. Press the SEQ button.

The camera LEDs light one at a time to indicate the corresponding camera is connected to the monitor. If a camera's LED is not lit, it has been programmed to bypass the sequence. Separate sequences can be run simultaneously on both monitors.

To stop a sequence:

1. Push the MON 1 or MON 2 button to select the monitor on which you want to stop the sequence.
2. Press any camera button.

The camera's corresponding LED illuminates, sequencing stops, and the selected camera's input appears on the monitor.

VIEWING THE STATUS OF CAMERAS IN A SEQUENCE

1. Press the MON 1 or MON 2 button.
2. Press and hold the GLOBAL and BYPASS buttons until the Sequence Status display appears on the monitor.
3. Release the GLOBAL and BYPASS buttons. If there is an asterisk under a camera on the monitor, that camera is IN the sequence. If there is no asterisk, that camera is OUT of the sequence. Refer to Figure 7.
4. Repeat steps 2 and 3 to exit the Sequence Status mode.

CHANGING THE STATUS OF A SINGLE CAMERA IN A SEQUENCE

Camera inputs not used may be bypassed from the sequence. Likewise, cameras that are bypassed can be put back into the sequence. To change the status of a camera:

1. Press the MON 1 or MON 2 button.
2. Press a camera button. If the camera LED is on steady, it is IN the sequence. If the camera LED is blinking, it is OUT of the sequence.
2. Press the BYPASS button to toggle the status of the camera.

CHANGING THE STATUS OF MULTIPLE CAMERAS IN A SEQUENCE

Camera inputs not used may be bypassed from the sequence. Likewise, cameras that are bypassed can be put back into the sequence. To change the status of cameras:

1. Press the MON 1 or MON 2 button.
2. Press and hold the GLOBAL and BYPASS buttons until the Sequence Status display appears on the monitor.
3. Release the GLOBAL and BYPASS buttons.
4. Press the camera buttons to toggle the status of the cameras. Refer to Figure 7.
5. Repeat steps 2 and 3 to exit the Sequence Status mode.

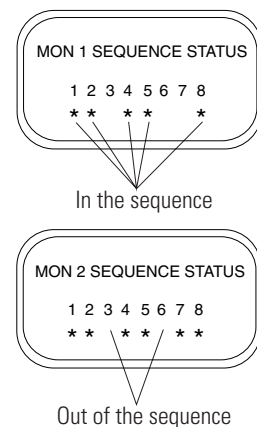

Figure 7. Camera Status

DWELL TIME

The time between switching from one camera to another is known as the dwell time. The dwell time can be set differently for each camera or it can be set the same (global) for all cameras on a monitor.

To check the dwell time:

1. Select a camera by pressing the button for that camera.
2. Press the camera button again. A number appears on the monitor indicating the dwell time from 1 to 60 seconds.

To set the dwell time:

1. Press the MON 1 button.
2. Global Dwell Setting - Press and hold the GLOBAL button. Proceed to step 3. Individual Dwell Settings - Press and hold the desired CAMERA button. Proceed to step 3.
3. Press and hold the TIME button. The timer displays a count in the lower left corner of the monitor, beginning at 1. The timer counts to 60. Each number represents the dwell time from a minimum of 1 second to a maximum of 60 seconds.
4. Release the TIME button at the dwell time you desire. The count does not wrap around, so if you miss your desired count, just release the TIME button, then press the TIME button again to restart the count.
5. Release the GLOBAL/CAMERA button.
6. Verify the dwell setting by pressing the camera button of whichever camera is currently selected. The dwell time appears on the monitor.
7. Repeat steps 2-6 for each camera for individual dwell times.
8. Press the MON 2 button if you have a second monitor and repeat steps 2-7. Both monitors can have different global dwell times.

CAMERA TITLING

You can program titles for each camera. The titles appear on the monitor screen.

To program or change camera titles:

1. Press the MON 1 or MON 2 button for the monitor on which camera titles appear. Camera titles appear on one monitor only. The monitor on which the titles appear is determined by the position of jumpers inside the switcher. Refer to Figure 1 and Table A.
2. Press and hold the GLOBAL button and camera button. A blinking cursor in the camera title indicates that you are in the edit mode for camera titling.
3. Release the GLOBAL and camera buttons.
4. Enter the camera title. Up to twenty characters can be entered. The blinking cursor indicates its current position. Press the TIME button to scroll forward through the character set. Press the GLOBAL button to scroll backward through the character set. Press the SEQ button to move the cursor one space to the right. Press the BYPASS button to move the cursor one space to the left.
5. When you have finished entering the camera title, do one of the following:
 - a. Press the camera button to select another camera. The camera title is saved and you are ready to edit the title of the camera you just selected.
 - b. Press the button of the camera that is currently selected. The camera title is saved and you exit the camera's programming mode.

ALARMS

The alarm inputs must be enabled or disabled if you connected alarms on the switcher to them.

To enable or disable alarms:

1. Press the MON 1 button.
2. Press the recessed ALARM switch. The switch toggles the alarm inputs on and off. When the ON LED is lit, the alarm inputs are enabled. When the ON LED is out, the alarm inputs are disabled. The switch enables or disables all alarm inputs.
3. Press the MON 2 button, then press the ALARM switch to enable or disable the alarms for monitor 2.

When there is an alarm, the switcher displays video on the monitor that corresponds to the alarm input. For example, if there is an alarm on input 3, the switcher displays video from camera 3. If there are multiple alarms, the switcher sequences between the alarms every second.

EXTERNAL TRIGGER

The external trigger allows the switcher to accept a signal from a time-lapse VCR to control the sequencing of cameras. The recessed EXT TRIG switch toggles the external trigger on and off. When the LED is lit, the external trigger is enabled. When the LED is out, the external trigger is disabled.

Camera input switching occurs every time a positive logic pulse (ground to +5 V) is sensed on the external trigger input. The maximum rate of sequencing is every 16.7 ms, which allows capture of one field of video between switching. The external trigger activates switching on both monitor outputs. In the alarm mode, the external trigger overrides the alarm sequencing dwell time.

POWER-UP DEFAULT SETTINGS

On power up, the default settings retain the configurations for camera sequences, but require that any sequence be manually started. For a sequence to start automatically during power-up, the unit must be programmed to remember the default settings.

To program the default setting that you want upon restoration of power:

1. Operate the unit in the desired default setting.
2. Press and hold the GLOBAL button and momentarily press the SEQ key. The new default setting is stored.
3. Release the GLOBAL button.

TROUBLESHOOTING

PROBLEM	SOLUTION
No power	Check the fuse .
Video output quality poor (Examples: Squiggly video, poor contrast, picture not centered)	Check jumper settings (Refer to Figure 1, Table A).
Locked system or sequencing not working as desired	Reset the switcher.

There are two types of reset operations:

1. Restart operation without erasing any programmed settings or sequences. If the switcher “locks up” and does not respond to normal operational controls, press the recessed RESET button on the front panel to restart operation.
2. Return the switcher to its default settings and then restart operation. Be careful if you perform this reset. Any programmed settings or sequences will be lost.

The default settings:

Camera 1	Selected
Sequencing	None
Alarms	Disabled
External Trigger	Disabled
Dwell Time	1 second

To reset the switcher to its default settings:

- a. Press and hold the GLOBAL button.
- b. Press the RESET button.
- c. Release the RESET button.
- d. Continue pressing the GLOBAL button while the unit resets. All LEDs turn off. When the reset is complete, the LED for the monitor lights and the LED for camera 1 lights.
- e. Release the GLOBAL button.

Table C. Fuse Table

MODEL	120 VAC Units	230 VAC Units
VA6204	1/10	1/10
VA6208	1/4	1/8
VA6212	1/10	1/10
VA6220	1/8	N/A

All fuses are 5 x 20 mm, 250V, slow-blow.

SPECIFICATIONS

VIDEO

Inputs: Terminating (75 ohms) or looping (high impedance) NTSC and PAL compatible

Outputs

Monitor 1: 75 ohms

Monitor 2: 75 ohms; half duplex (Coaxitron® compatible). Requires field jumper change

Gain: Unity

Dwell: Camera dwell independently adjustable from 1 to 60 seconds nominal

Frequency

Response: 10 MHz

Maximum

Signal Level: 1.5 Vp-p

Tilt: Less than 2%

Character

Generation: Available on monitor 1 or 2

Crosstalk: Better than -43 dB at 10 MHz

ELECTRICAL

Input Voltage: 120 VAC, 60 Hz (NTSC) or 230 VAC, 50 Hz (PAL)

Rated Current:

VA6204: 25 mA

VA6208: 40 mA

VA6212: 50 mA

VA6220: 75 mA

Power

VA6204: 2 vA

VA6208: 4 vA

VA6212: 6 vA

VA6220: 8 vA

Alarm In: Ground alarm inputs to enable alarm. Open or +5 VDC maximum input to disable alarm

Alarm Out: Dry contact relay, normally open contacts. 1A at 30 VDC, 0.5A at 125 VAC and 0.3A at 80 VDC

Connectors: BNC

GENERAL

Construction

Chassis: Steel, zinc plated
Cover: Steel, textured black enamel
Panel: Aluminum, with LEXAN® overlay

Dimensions

VA6204 Series: 1.75 (H) x 5.50 (W) x 9.25 (D) inches (4.44 x 13.97 x 23.49 cm)
VA6208 Series: 1.75 (H) x 8.75 (W) x 11.75 (D) inches (4.44 x 22.23 x 29.84 cm)
VA6212 Series: 1.75 (H) x 14.25 (W) x 9.25 (D) inches (4.44 x 36.19 x 23.49 cm)
VA6220 Series: 1.72 (H) x 17.47 (W) x 8.78 (D) inches (4.37 x 44.37 x 22.30 cm)

Rating: NEMA 1

Environment: 32° to 120°F (0° to 49°C)

(Design and product specifications subject to change without notice.)

PRODUCT WARRANTY AND RETURN INFORMATION

WARRANTY

Pelco will repair or replace, without charge, any merchandise proved defective in material or workmanship for a period of one year after the date of shipment.

Exceptions to this warranty are as noted below:

- Five years on FT/FR8000 Series fiber optic products.
- Three years on Genex® Series products (multiplexers, server, and keyboard).
- Three years on Camclosure® and fixed camera models, except the CC3701H-2, CC3701H-2X, CC3751H-2, CC3651H-2X, MC3651H-2, and MC3651H-2X camera models, which have a five-year warranty.
- Two years on standard motorized or fixed focal length lenses.
- Two years on Legacy®, CM6700/CM6800/CM9700 Series matrix, and DF5/DF8 Series fixed dome products.
- Two years on Spectra®, Esprit®, ExSite™, and PS20 scanners, including when used in continuous motion applications.
- Two years on Esprit® and WW5700 Series window wiper (excluding wiper blades).
- Two years (except lamp and color wheel) on Digital Light Processing (DLP™) displays. The lamp and color wheel will be covered for a period of 90 days. The air filter is not covered under warranty.
- Eighteen months on DX Series digital video recorders, NVR300 Series network video recorders, and Endura™ Series distributed network-based video products.
- One year (except video heads) on video cassette recorders (VCRs). Video heads will be covered for a period of six months.
- Six months on all pan and tilts, scanners or preset lenses used in continuous motion applications (that is, preset scan, tour and auto scan modes).

Pelco will warrant all replacement parts and repairs for 90 days from the date of Pelco shipment. All goods requiring warranty repair shall be sent freight prepaid to Pelco, Clovis, California. Repairs made necessary by reason of misuse, alteration, normal wear, or accident are not covered under this warranty.

Pelco assumes no risk and shall be subject to no liability for damages or loss resulting from the specific use or application made of the Products. Pelco's liability for any claim, whether based on breach of contract, negligence, infringement of any rights of any party or product liability, relating to the Products shall not exceed the price paid by the Dealer to Pelco for such Products. In no event will Pelco be liable for any special, incidental or consequential damages (including loss of use, loss of profit and claims of third parties) however caused, whether by the negligence of Pelco or otherwise.

The above warranty provides the Dealer with specific legal rights. The Dealer may also have additional rights, which are subject to variation from state to state.

If a warranty repair is required, the Dealer must contact Pelco at (800) 289-9100 or (559) 292-1981 to obtain a Repair Authorization number (RA), and provide the following information:

1. Model and serial number
2. Date of shipment, P.O. number, Sales Order number, or Pelco invoice number
3. Details of the defect or problem

If there is a dispute regarding the warranty of a product which does not fall under the warranty conditions stated above, please include a written explanation with the product when returned.

Method of return shipment shall be the same or equal to the method by which the item was received by Pelco.

RETURNS

In order to expedite parts returned to the factory for repair or credit, please call the factory at (800) 289-9100 or (559) 292-1981 to obtain an authorization number (CA number if returned for credit, and RA number if returned for repair).

All merchandise returned for credit may be subject to a 20% restocking and refurbishing charge.

Goods returned for repair or credit should be clearly identified with the assigned CA or RA number and freight should be prepaid. Ship to the appropriate address below.

If you are located within the continental U.S., Alaska, Hawaii or Puerto Rico, send goods to:

Service Department
Pelco
3500 Pelco Way
Clovis, CA 93612-5699

If you are located outside the continental U.S., Alaska, Hawaii or Puerto Rico and are instructed to return goods to the USA, you may do one of the following:

If the goods are to be sent by a COURIER SERVICE, send the goods to:

Pelco
3500 Pelco Way
Clovis, CA 93612-5699 USA

If the goods are to be sent by a FREIGHT FORWARDER, send the goods to:

Pelco c/o Expeditors
473 Eccles Avenue
South San Francisco, CA 94080 USA
Phone: 650-737-1700
Fax: 650-737-0933



This equipment contains electrical or electronic components that must be recycled properly to comply with Directive 2002/96/EC of the European Union regarding the disposal of waste electrical and electronic equipment (WEEE). Contact your local dealer for procedures for recycling this equipment.

REVISION HISTORY

Manual #	Date	Comments
C841M	12/99	Original version.
C841M-A	7/02	Updated manual to new format. Removed reference to alarm breakout panel.

Pelco, the Pelco logo, Camclosure, Esprit, Genex, Legacy, and Spectra are registered trademarks of Pelco. Endura and ExSite are trademarks of Pelco. DLP is a trademark of Texas Instruments, Inc

© Copyright 2002, Pelco.
All rights reserved.



World Headquarters
3500 Pelco Way
Clovis, California 93612 USA

USA & Canada
Tel: 800/289-9100
Fax: 800/289-9150

International
Tel: 1-559/292-1981
Fax: 1-559/348-1120

www.pelco.com

ISO9001

Orangeburg, New York | Las Vegas, Nevada | Eindhoven, The Netherlands | Wokingham, United Kingdom | Montreal, Canada